



# Architectural Dimmers

## Features

- Simple zone controls
- No visible mounting hardware
- Single button activates station
- Remote lock-out option available
- Stations may be daisy-chained together
- Take Control and Full On option available
- Utilizes simple analog control for easy installation
- Wallplates mount in standard masonry backboxes
- Simple to operate -- linear control with 45mm travel
- Custom color faceplates and nomenclature available
- Master slider on systems with three or more channels
- Custom faceplates with nine or more channels available

## Designer Series Wallplates

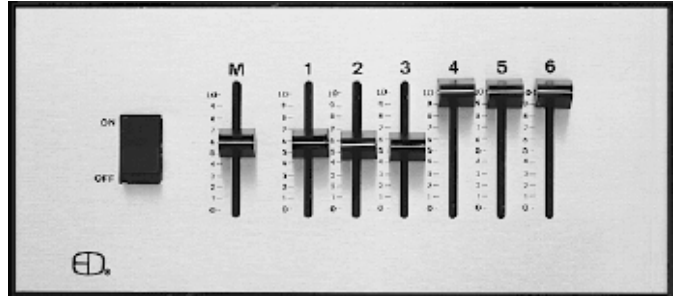

## Description

The Designer Series wallplates allow for multiple location control of one or more lighting channels by a combination of slide potentiometers, switches, and pushbuttons. Control of each channel is available from its corresponding slider.

Wallplates with three or more channels include a proportional master slider to simultaneously control all channels. An Off, Take Control and/or Full switch allows lights to be turned off or selected full on without disturbing the slider settings.

Easy to operate, the Designer Series control station wallplates add low-profile lighting control to any room.

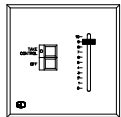

D Series 301  
1-Channel

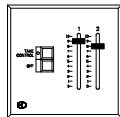

D Series 302  
2-Channel

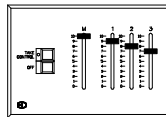

D Series 303 3-  
Channel with Master

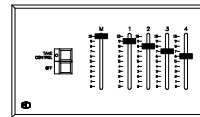

D Series 304 4-  
Channel with Master

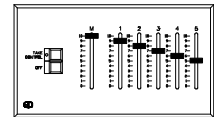

D Series 305 5-  
Channel with Master

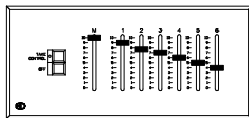

D Series 306 6-  
Channel with Master

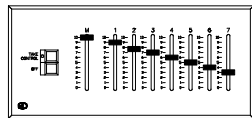

D Series 307 7-  
Channel with Master

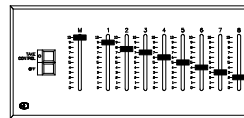

D Series 308 8-  
Channel with Master

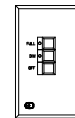

D Series Walk-thru

## Order Information:

### Control Stations:

- On/Off (2)
- Take Control (3)
- Full (4)

### Control Stations w/Master On/Off Switch

- D( )00 Walk-thru
- D( )01 1-Channel
- D( )02 2-Channel
- D( )03 3-Channel
- D( )04 4-Channel
- D( )05 5-Channel
- D( )06 6-Channel
- D( )07 7-Channel
- D( )08 8-Channel

### Custom:

- Designer Series:
- Colors
- Channels

Job Number:

Customer:

Approval Stamp:

Job Name:

P.O.:

Electronics Diversified, Inc.

PRODUCT DATA SHEET

1675 N.W. Cornelius Pass Road • Hillsboro, Oregon 97124 U.S.A.  
Phone: (503) 645-5533 • FAX: (503) 629-9877 • Web Site: www.edionline.com

A300



## Electrical & Wiring Data

- Control Voltage: 10 Volts DC  
 Conductor type: 18 AWG
- A. All wiring is Class II.
  - B. Ten percent spare wire count recommended.
  - C. All connections to wallplate are by labeled wires.
  - D. Other configurations available -- consult factory.

## Dimensions

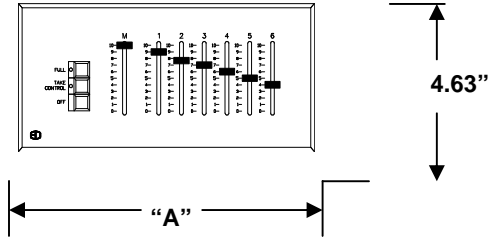

Model #: (2), (3), (4)	Type of Control:		
	(2) On/Off	(3) Take Control	(4) Full
D 01	3	5	6
D 02	4	6	7
D 03	5	7	8
D 04	6	8	9
D 05	7	9	10
D 06	8	10	11
D 07	9	11	12
D 08	10	12	13
D 09-up	For more than 8 sliders, consult factory		

Model No.	Dim "A"	Wallbox Size	
		Width	Height
D 01	4.63"	3.78"	3.75"
D 02	4.63"	3.78"	3.75"
D 03	6.45"	5.60"	3.75"
D 04	8.28"	7.41"	3.75"
D 05	8.28"	7.41"	3.75"
D 06	10.14"	9.22"	3.75"
D 07	10.14"	9.22"	3.75"
D 08	10.14"	9.22"	3.75"
D 09-up	Consult factory for dimensions		

## Riser Diagram

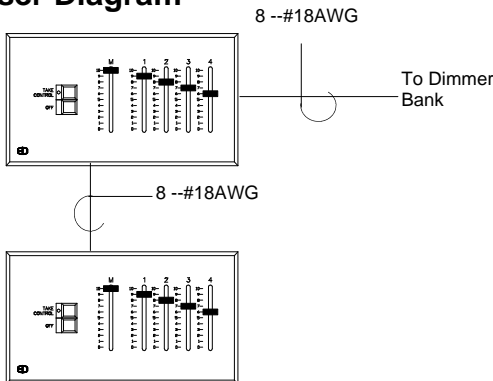

## Mounting

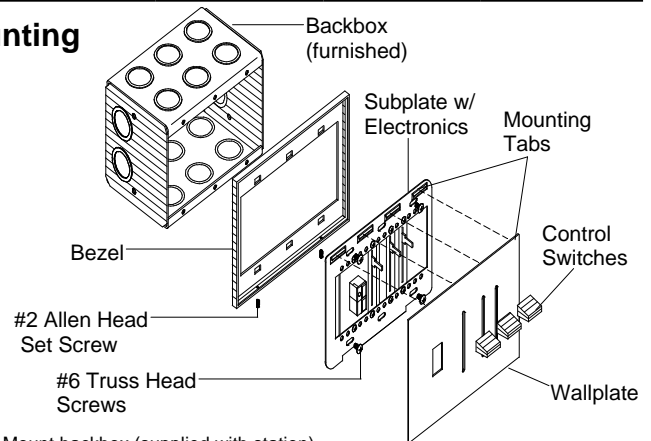

1. Mount backbox (supplied with station).
2. Route wires from backbox through bezel and connect to electronics on subplate.
3. Align bezel and subplate and attach to backbox, using #6 truss-head screws (furnished).
4. Slip wallplate mounting tabs under corresponding subplate tabs.
5. Fasten wallplate to subplate with allen head set-screws located on bottom of bezel. Turn set-screws until resistance is felt. DO NOT TIGHTEN.

## Specifications

1. The control station surface shall be constructed of brush-finished aluminum. All components shall mount to this plate. A slim-line designer frame shall border this plate.
2. There shall be no visible means of mounting from the front of the plate. Velcro or magnetic means of mounting shall not be acceptable.
3. The plate shall mount into a standard masonry back box provided by the manufacturer.
4. The control plate shall have \_\_\_\_\_ channels of control. Each channel shall be controlled by a slider with a minimum 45mm. travel. Wall plates with three or more channels shall also have a proportional master slider.
5. (Select one of the following): (2); (3); or (4):
  2. An Off/On rocker switch shall activate control at the station when only one station controls the selected channels.
3. There shall be an Off/Take control switch with LED active when the channels have more than one point of control. Selecting Take Control will place the station on line and force light levels to be a proportion of the master level on the station.
4. In addition to the Take Control switch, an optional Full switch allows the selection of all On without disturbing current slider settings. All control station analog wiring shall be 18-gauge.
7. The control voltage shall be 0 - 10 Volts DC.
8. The wallplate shall be the Designer Series, Model \_\_\_\_\_ as manufactured by Electronics Diversified, Inc., Hillsboro, Oregon, 97124, USA.